

WALL MOUNTED DRINKING FOUNTAIN

PRODUCT CODE
CWS WMDF 461

APRIL 2016

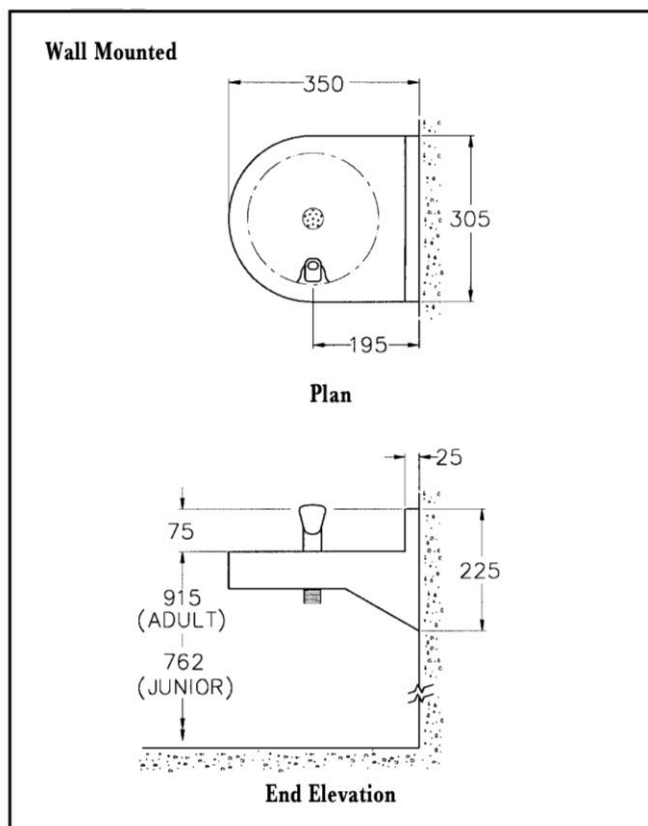

Installation

The drinking fountain should be installed with the top edge horizontal and the edges sealed against the wall with a permanent impermeable joint.

The drinking fountain should be fitted to the wall at a height shown on the drawing. The wall-mounting bracket should be screwed to the wall in a horizontal position, the drinking fountain mounted on it, and then secured to the wall through the fixing holes at the rear of the body using suitable fasteners for the wall construction.

The flush grated waste fitting and the bubbler valve should be fitted into the appropriate holes. The black rubber washer should be fitted over the brass inlet nipple and located into the recess in the base of the bubbler valve body. The valve body should be fitted into the hole on the fountain top ensuring that the anti-rotation pin is engaged into the notch.

The valve should be secured from underneath the fountain top using the stainless steel washer and brass nut. A coupler is provided to connect the inlet nipple to 15mm dia pipe. A suitable thread sealant approved for potable water should be used. The waste fitting should be connected to a proprietary trap and waste pipe.

Prior to final connection the water supply pipe should be flushed through to ensure that no debris is allowed to enter the valve cartridge which may affect its performance.

Water Flow Adjustment

Removing the chrome-plated nut around the push button and adjusting the screwdriver slot underneath can alter the height of the water jet. This can be completed with the water connected.

Earthing Continuity

All drinking fountains are provided with a number of fixing points on to which an earthing continuity wire with an end terminal can be secured.

Warning

If the drinking fountain is to be mounted outside, in accordance with good plumbing practice the supply and valve should be isolated and drained down during winter months to prevent freezing.

Unit 1, Elphicks Farm, Spelmonden Road, Horsmonden, Tonbridge. Kent TN12 8EL
Phone: 01580 211648 E-mail: info@cactuswatersystems.co.uk

Cactus Water Systems / the manufacturer reserve the right to change the design and specification of goods without notice. Descriptions in this sheet are correct at time of going to press but are subject to alteration. Details of any changes will be available